

Pneumatic Stop Cylinders

Pneumatic stop cylinders with hydraulic industrial shock absorbers for soft, rebound-free stopping of a conveyed load.

Pneumatic Stop Cylinders

- Soft, rebound-free stopping of a conveyed load.
- Flexible: for vertical or horizontal installation
- Types with shock absorber/roller lever combination, lone roller or roller with a piston rod that ensures direct stoppage
- Shock absorbers are easy to replace, even when fitted
- Rotating stop head for adjustment in line with the direction of travel of the conveyed load
- Rocker can be deactivated for alternate travel function
- Single and double acting cylinder variants
- Operating pressure up to 10 bar
- Different shock absorbers for conveyed load weights of up to 1700 kg and speeds of up to 45 m/min
- Optional: position switch for piston rod and proximity switch for rocker

Rocker locking

After the conveyed load is stopped, the rocker is lowered and unlocked by applying compressed air. After the conveyed load has been moved, the return spring brings the rocker into its upper end position so that it is back in its start position for the next stopping procedure.

Integrated shock absorbers

The shock absorbers, aligned to the weight and speed of the load, ensure gentle and precise stopping of the conveyed load

Guide rod

Thanks to the easy-to-replace guide rod, the rocker can be quickly rotated so that the conveyor can move in a different direction.

Diecast Aluminum

The design of the robust, lightweight diecast aluminum and its compact size enables it to be installed in many different conveyor systems.



Unrestricted conveyor movement

The rocker is held in the OFF position (deactivated) by simply clipping a spring steel sheet onto it. The conveyed load can pass through the stop cylinder unobstructed while the rocker is in this position.



Stop Cylinder – Vertical Version

STVSR series



Integrated shock absorber for heavy conveyed loads

The built-in shock absorber stops the conveyed load in a gentle and precise manner without disturbing the load. Various shock absorbers are available depending on the weight of the conveyed load and the desired transport speed.

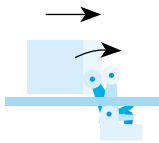

STVDR series



Roller for lower conveyed load weights

The piston rod with upward facing roller is lowered by applying compressed air once the conveyed load is on the ground. Afterwards, it is brought back into the upper end position by a return spring.

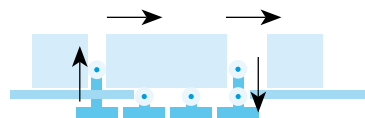

STVD series



Direct stopping piston rod for heavy conveyed loads

Reliably stops heavy conveyed loads at low transport speeds. Can also be used as a locking cylinder due to its solid piston rod.

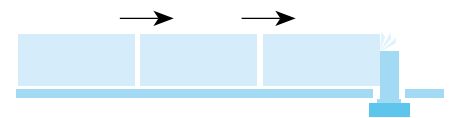

Stop Cylinder – Horizontal Version

STHSR series

Horizontal stop cylinder with shock absorber

Reliably stops heavy conveyed loads at high transport speeds. Well-suited for buffer areas.

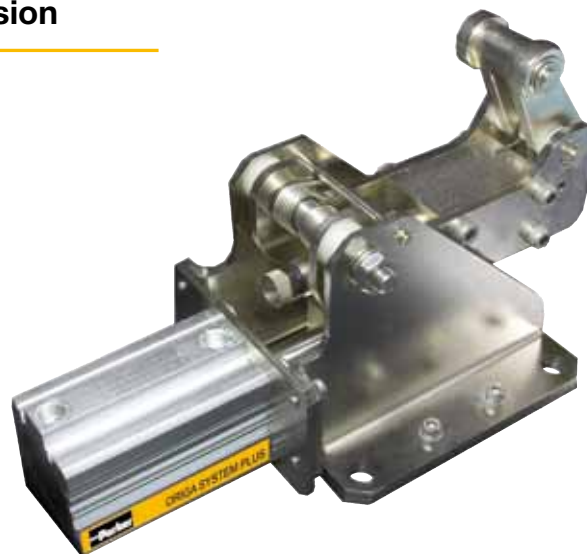

Pneumatic Stop Cylinders

Ø 50-80 mm

Available with hydraulic Industrial shock absorbers

Vertical Version:

- STVSR series
- STVDR series
- STVD series

Horizontal Version:

- STHSR series



Vertical versions

Vertical stop cylinder with shock absorber and roller lever



Cylinder Ø mm	Stroke (mm)	Order code
50	30	STVSR-50-30-.-...
80	40	STVSR-80-40-.-...

Vertical stop cylinder with roller



Cylinder Ø mm	Stroke (mm)	Order code
50	30	STVDR-50-30-.-...

Vertical stop cylinder with direct stopping piston rod



Cylinder Ø mm	Stroke (mm)	Order code
50	30	STVD-50-30-.-...

Horizontal versions

Horizontal stop cylinder with shock absorber and roller lever



Cylinder Ø mm	Stroke (mm)	Order code
50	50	STHSR-50-50-.-...

Pneumatic Circuit Diagrams

Single acting

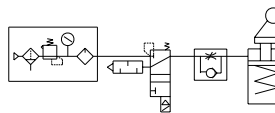

Double acting

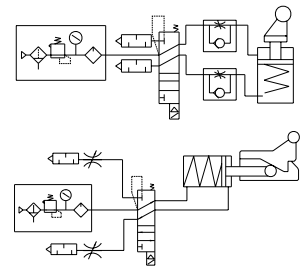

Specifications

Specifications	Description
Medium	Filtered, unlubricated compressed air (if oil is used then it must be continued)
Operating pressure range	2 to 10 bar
Test pressure	15 bar
Ambient temperature range	0 °C to +65 °C (If intended for use below 0 °C consult Technical Sales)
Lubrication	Unlubricated
Cushioning	Cushioning mat made from oil-resistant rubber

Weight

Type STVSR-50-30	1.800 kg
Type STVSR-80-40	6.820 kg
Type STVDR-50-30	1.800 kg
Type STVD-50-30	1.800 kg
Type STHSR-50-50	8.750 kg

STVSR Series - Stop cylinder Ø 50mm - Vertical version

Order Key

STVSR - 50 - 30 - L - STD

Shock absorber strength	
L	Light 50 - 150 kg
H	High 150 - 300 kg

Connecting thread	
STD	Standard G1/8
NPT	National Pipe Thread 1/8"

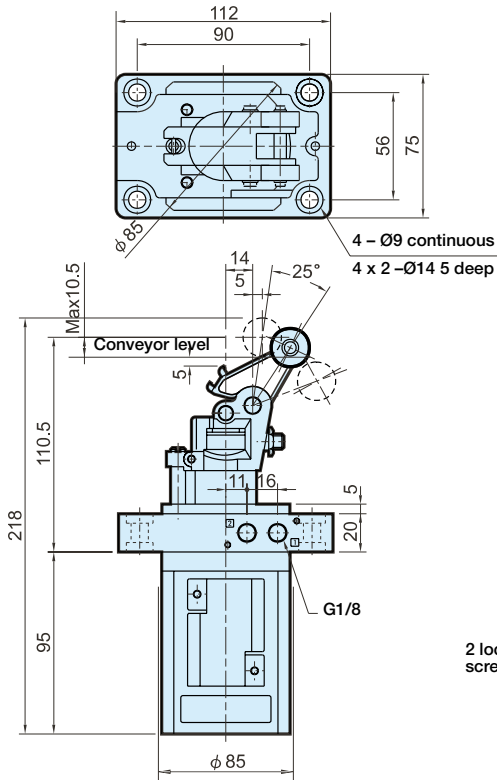

Option - Rocker locking

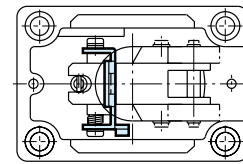

- Free travel of conveyed load

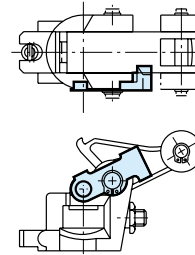

Loads - Moving mass subject to speed – Type STVSR-50-30

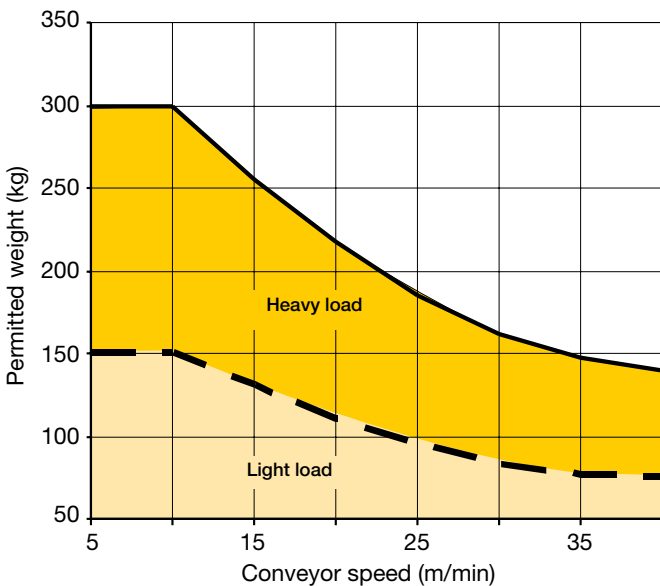

Axial load subject to operating pressure – Type STVSR-50-30

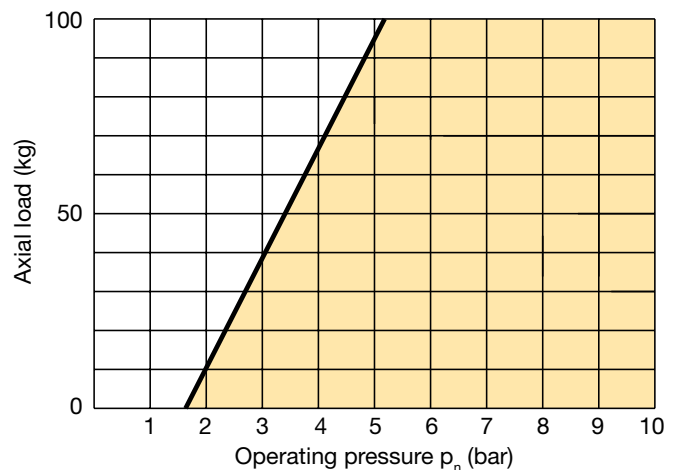

STVSR Series - Stop cylinder Ø 80mm - Vertical version

Order Key

STVSR - 80 - 40 - STD

Note: Shock absorbers can set at 50 - 800kg

Connecting thread	
STD	Standard G1/4
NPT	National Pipe Thread 1/4"

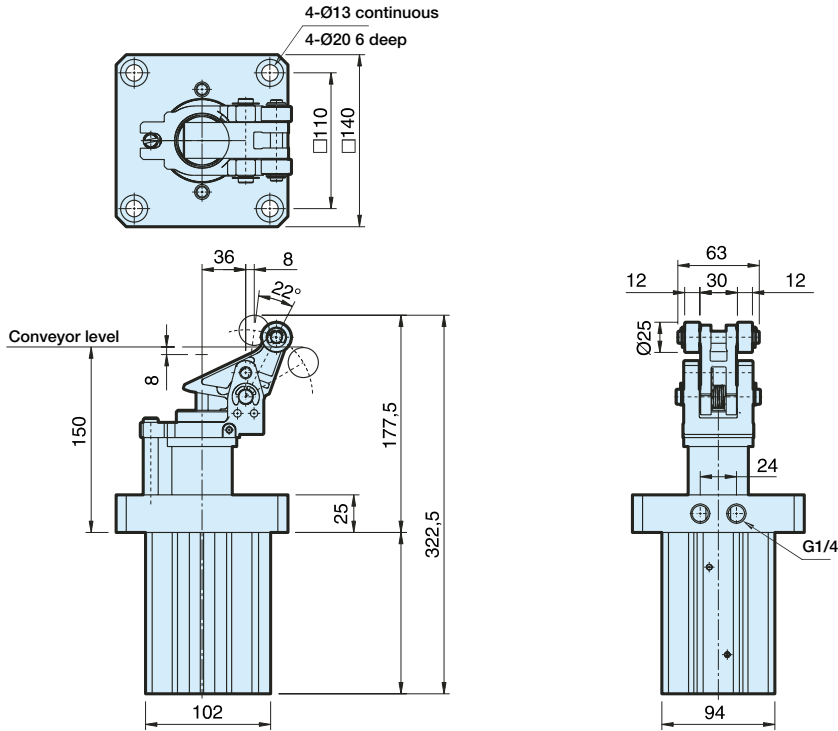

Loads - Moving mass subject to speed – Type STVSR-80-40

Axial load subject to operating pressure – Type STVSR-80-40

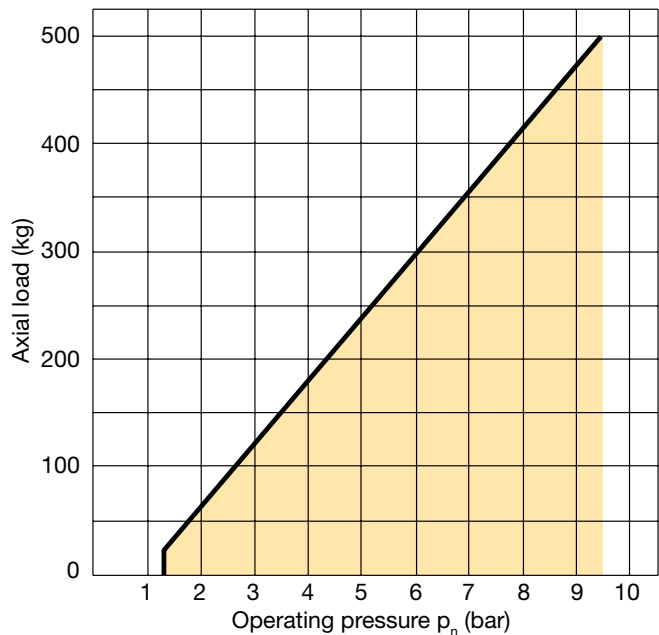
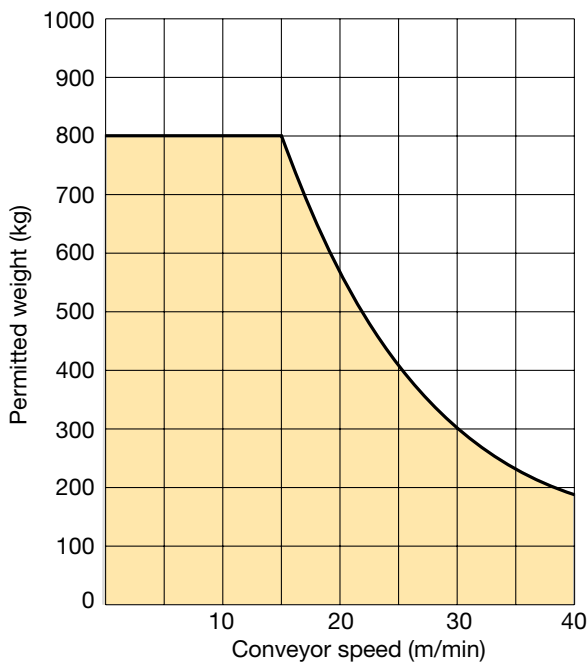

STVDR Series - Stop cylinder Ø 50mm - Vertical version

Order Key

STVDR - 50 - 30 - STD

Connecting thread	
STD	Standard G1/8
NPT	National Pipe Thread 1/8"

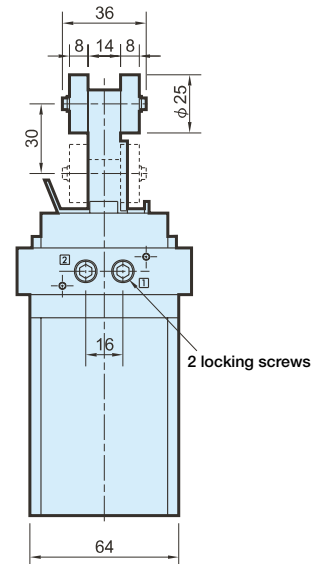
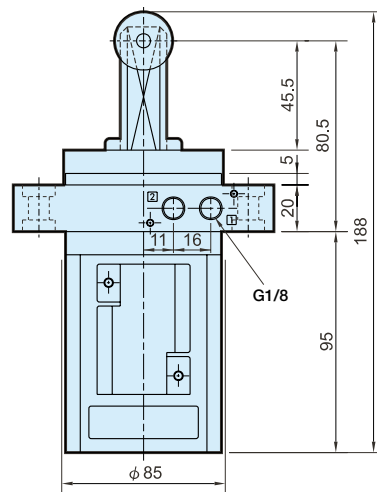
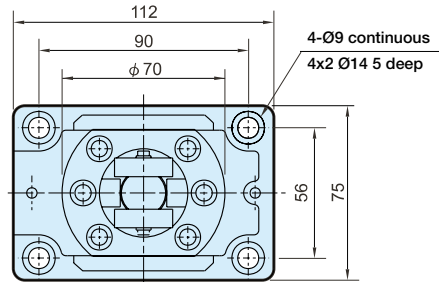

Loads - Moving mass subject to speed – Type STVDR-50-30

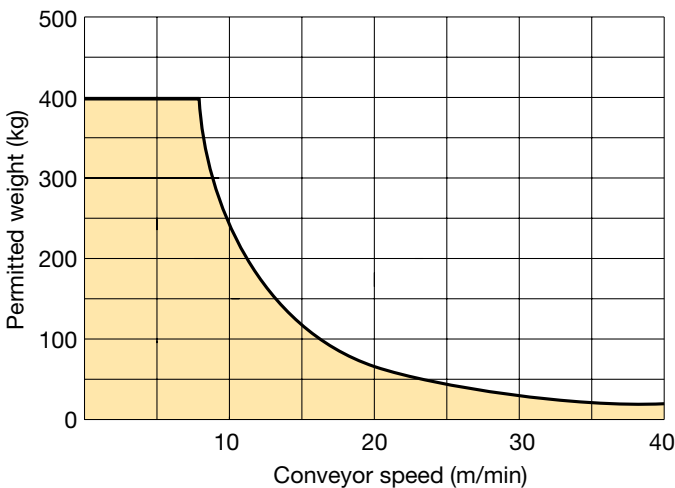

Axial load subject to operating pressure – Type STVDR-50-30

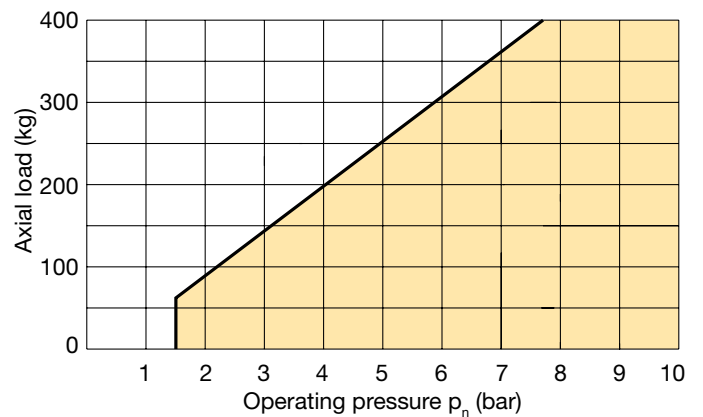

STVSR Series - Stop cylinder Ø 80mm - Vertical version

Order Key

STVD - 50 - 30 - STD

Connecting thread	
STD	Standard G1/8
NPT	National Pipe Thread 1/8"

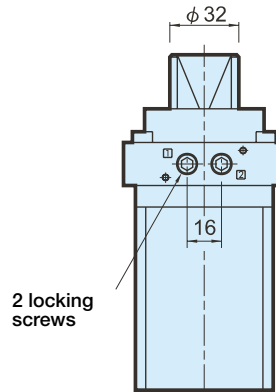
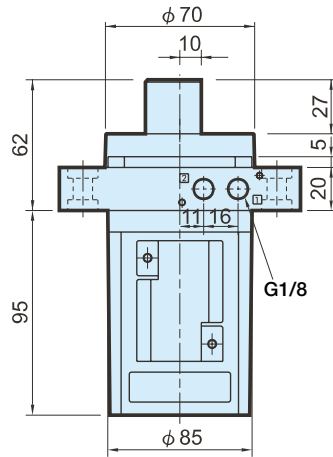
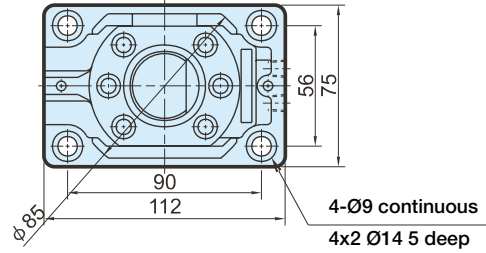

Loads - Moving mass subject to speed – Type STVD-50-30

Axial load subject to operating pressure – Type STVD-50-30

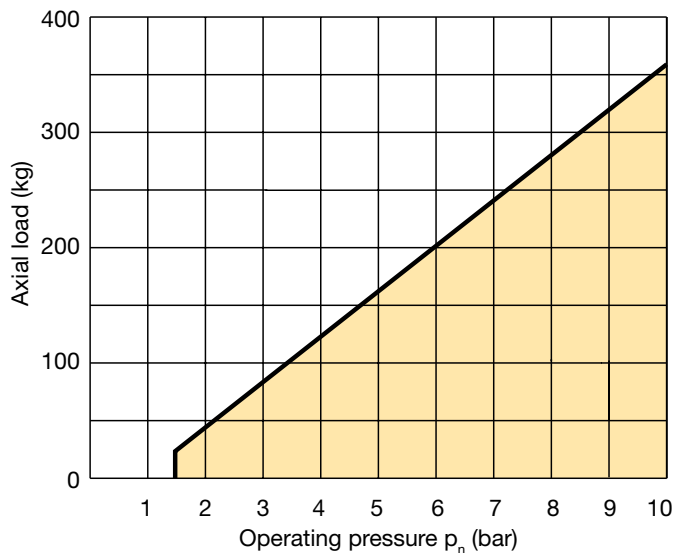
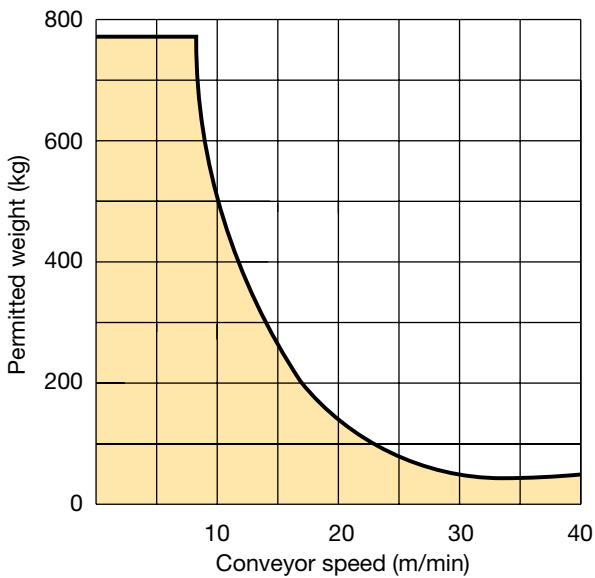

STHSR Series - Stop cylinder Ø 50mm - Horizontal version

Order Key

STHSR - 50 - 50 - STD

Connecting thread	
STD	Standard G1/4
NPT	National Pipe Thread 1/4"

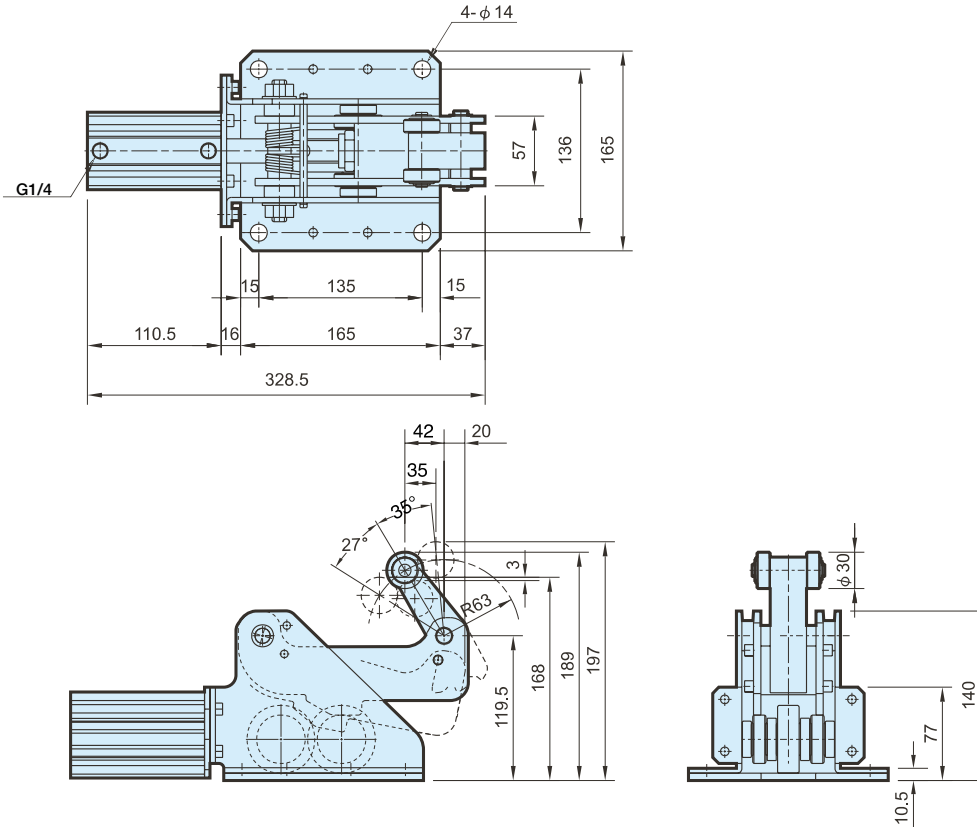

Loads - Moving mass subject to speed – Type STHSR-50-50

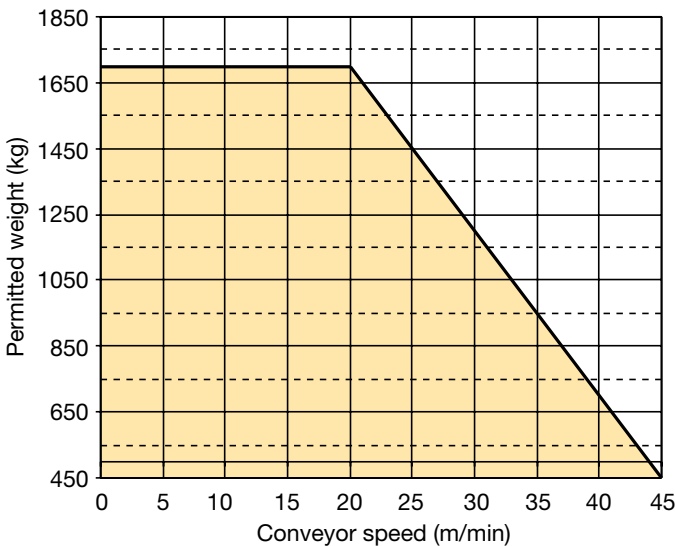

Axial load subject to operating pressure – Type STHSR-50-50

